

## CostGard™ CONDENSATE DRAIN SYSTEM DRAW-THROUGH HVAC UNIT SMALL HORIZONTAL FLOW

### APPLICABILITY

TYPE UNIT: UNITARY OR SPLIT  
 COOLING CAPACITY: UP TO 30 TONS  
 DRAIN DIAMETER: 3/4" AND 1"  
 DRAIN PAN PRESSURE: -1.5" WG OR LESS

### DRAIN SYSTEM COMPONENTS

DRAIN SEAL, GROMMETS, WARNING LABEL,  
 AND INSTALLATION INSTRUCTIONS.

FIELD SUPPLIED: PIPE, PIPE FITTINGS, AND  
 PIPE SUPPORTS. FOR OUTDOOR  
 INSTALLATIONS, UV INHIBITED PIPE AND PIPE  
 FITTINGS ARE RECOMMENDED.

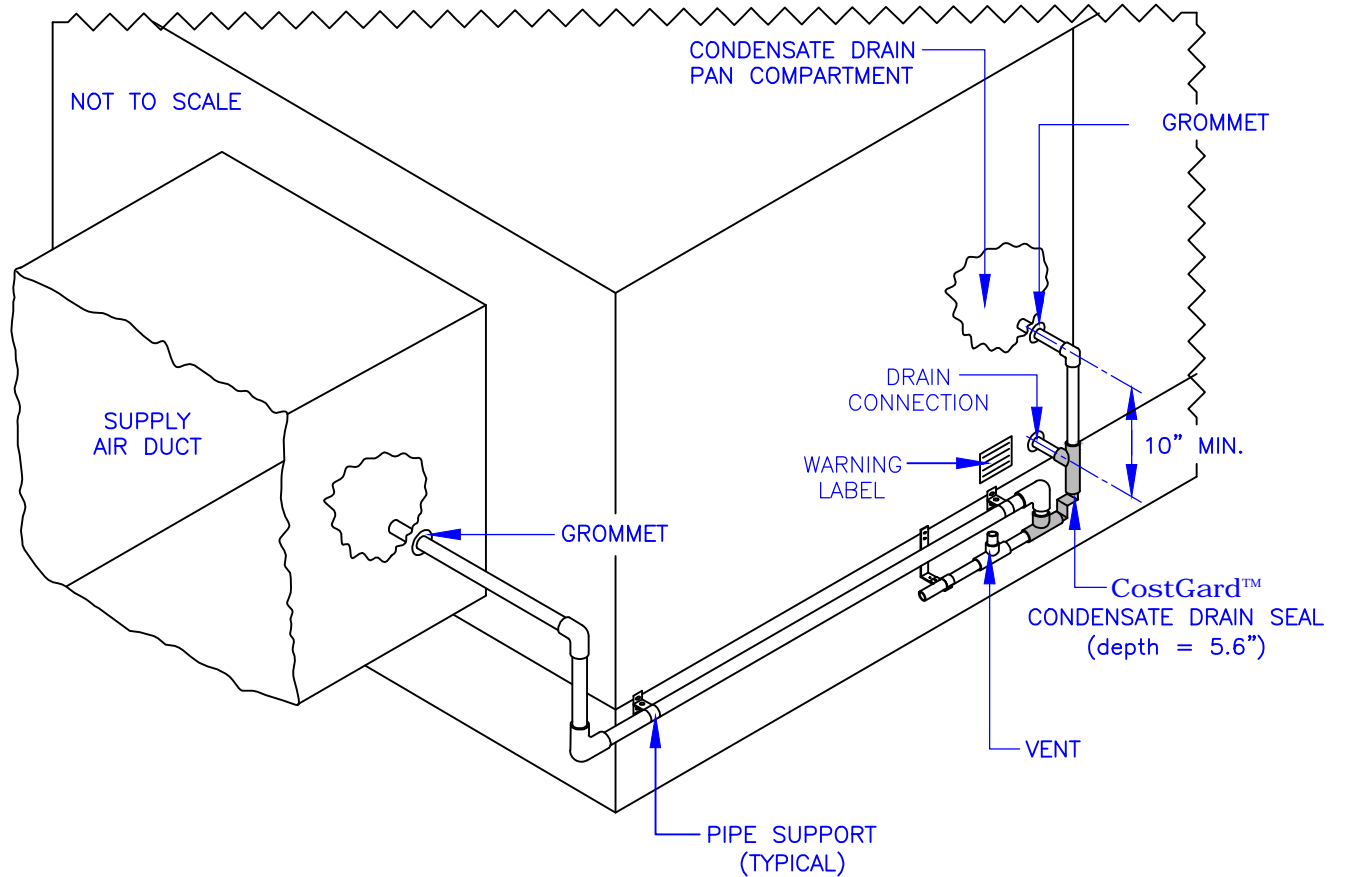

### GENERAL NOTES:

1. THIS IS A GENERIC DETAIL OF A SMALL AHU CONDENSATE DRAIN SYSTEM.
2. REFER TO MANUFACTURER FOR EXACT AHU MODEL AND PIPE CONFIGURATION: Email: info@trenttech.com; Phone: 903-509-4843.
3. REFER TO SECTION \_\_\_ ON DRAWING \_\_\_.
4. SEE ARCHITECTURAL DRAWINGS AND SPECIFICATIONS FOR ROOF CURB OR PAD, AND DRAIN PIPING.

DESCRIPTION:  
**CostGard™  
 CONDENSATE DRAIN SYSTEM**

CONFIDENTIAL PROPERTY OF  
**Trent Technologies, Inc.**  
 15939 OLD JACKSONVILLE HWY., TYLER, TX 75703  
 NOT TO BE DISCLOSED TO OTHERS, COPIED, OR  
 USED FOR ANY REASON EXCEPT AS AUTHORIZED.

SCALE: NONE	DOCUMENT NAME: DT-SHF	DATE: 3/10/14
UNLESS OTHERWISE SPECIFIED DIMENSIONS ARE IN INCHES		SHEET: 1 OF 1