

Submittal



CostGard™

Condensate Drain Seal
For
Ducted Draw-Through Air-Handlers
Unitary or Split

Light Commercial Kits—Up to 30 Tons

LC-15-25-X-X-56-10-XX-X-X-X

Commercial Kits—Up to 100 +Tons

C-XX-XX-XX-12-XX-20-XX-X-X

Unitary Rooftop System Kits—Up to 30 Tons

Designed for most Major Brands including:

- Aaon
- Carrier
- Lenox
- Trane
- York

Prepared by:
Trent Technologies, Inc.
15939 FM 2493, Tyler, TX 75703
903-509-4843



CostGard™ Condensate Drain Seal

Submittal Ducted Draw-Through

GENERAL

The CostGard™ Condensate Drain Seal was developed to replace the condensate trap on ducted draw-through HVAC systems. Unlike a condensate trap, it uses air instead of a water seal as a seal. It eliminates costly operational and health-related problems needlessly tolerated by facility managers for over half a century. It does this by reducing (1) service calls, (2) maintenance requirements, (3) damage to equipment, (4) damage to surrounding property, and (5) threats to healthy indoor air quality.

Operation

The CostGard™ Condensate Drain Seal results from over four years of engineering research and development. It uses the hydraulic and pneumatic forces present in all draw-through air handlers. It is simple, effective, and reliable, with no moving parts. Figure 1 illustrates how it operates.

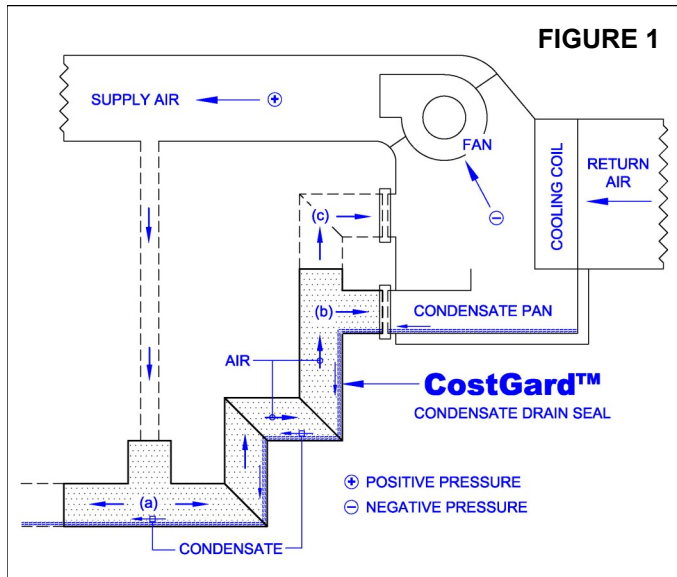

During both heating and cooling operations, the air seal is formed as follows:

The fresh air from the fan discharge is supplied to point (a) at a pressure slightly above atmospheric. Some of the air flows away from the HVAC unit, preventing the ingestion of outside air. A portion of the air returns to the HVAC unit, passing through points (b) and (c). The high-pressure loss in the mitered elbows minimizes the quantity of air returning to the unit. This pressure loss, combined with the air flowing through the bypass connected at point (c), ensures that the air entering the condensate drip pan does not cause blowing, geysing, or an aerosol mist. The condensate flows through the device without being trapped. At the same time, the counter-flow of condensate and air creates a pulsing action that ensures free passage of debris. As a result, the potential for freeze-up and flow blockage (common problems with traps) is eliminated.

Advantages Over a Trap

When used in place of a condensate trap, the CostGard™ Condensate Drain Seal significantly reduces the cost of owning and operating draw-through HVAC systems. It also removes a severe and significant contributor to poor indoor air quality. Many in the HVAC industry recognize the need to replace the condensate trap with an effective and reliable drain seal. Many of the problems caused by condensate traps are clearly stated in ASHRAE Standard 62-89R, paragraph 5.6.4, which reads as follows:

"Condensate traps exhibit many failure modes that can impact on indoor air quality. Trap failures due to freeze-up, drying out, breakage, blockage, and/or improper installation can compromise the seal against air ingestion through the condensate drain line. Traps with insufficient height between the inlet and outlet [design deficiency] on draw-through systems can cause the drain to back-up when the fan is on, possibly causing drain pan overflow or water droplet carryover into the duct system. The resulting moist surfaces can become sources of biological contamination. Seasonal variations, such as very dry or cold weather, may adversely affect trap operation and condensate removal."

The ASHRAE Standard addresses only "building ventilation and indoor air quality." However, the cost impact of trap failures on system maintenance and property damage is evident.

There are many causes of trap failures, which are much too familiar to facility managers and HVAC maintenance personnel. The maintenance effort required to deal with these destructive results is exceptionally demanding. Trap deficiencies are so numerous that successful maintenance is often not feasible. Indeed, in some instances, adequate maintenance is not realistically possible.

The CostGard™ Condensate Drain Seal eliminates all the problems caused by the condensate trap, including the following:

- Trap blockage and condensate pan overflow;
- Seal (trap) freeze damage in outside locations;
- Ingestion of odorous and toxic gases through the condensate drain system;
- Condensate pan overflow due to negative pressure during start-up;
- Condensate blowing, which produces an aerosol mist and causes biological contamination; and
- Shortened life of HVAC systems.

Eliminating these problems can result in enormous cost savings for the building owner due to fewer service calls, reduced maintenance effort, less property damage, increased equipment life, and improved indoor air quality.

PRODUCTS

The Draw-Through CostGard™ Condensate Drain Seal comes in two models: Light Commercial LC1525 and Commercial CXXXX. Both models are made of polyvinyl chloride (PVC). These models can be used for almost any draw-through HVAC system. CostGard™ Condensate Drain Seals are suitable for HVAC systems with the following characteristics:

1. Drain diameters up to 2.0 inches I.D. (nominal pipe dimensions);
2. Static pressure in the drain pan = -5.0 inches wc, or less; and
3. Cooling capacities up to 100+ tons.

Light Commercial LC1525

This model is available in four (4) variations which can accommodate drain diameters of 3/4" and 1 inch and operate with a negative static pressure in the drain pan of 1.5 inches wc or less. The model variations available are identified by the photograph and sketch in Figure 2.

The device consists of three parts, identified in Figure 2 as Parts A, B, and C. These parts provide versatility in installation. For example, by rotating Part C in Part A, the discharge port Part B can be pointed in various directions. Part B can also be rotated up to 60 degrees to allow piping alignment.

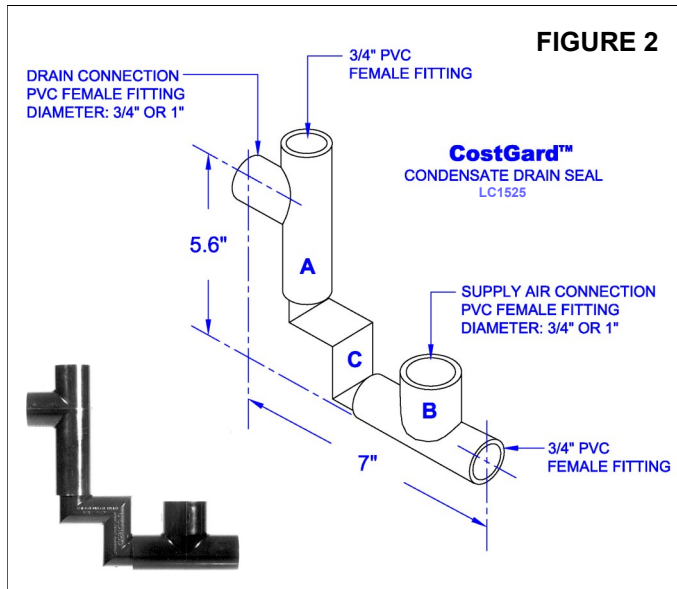

TABLE 1. LIGHT COMMERCIAL LC1525 CostGard™ CONDENSATE DRAIN SEAL UNITS WITH COOLING CAPACITIES UP TO 30 TONS

MAXIMUM NEGATIVE DRAIN PAN PRESSURE	MODEL NUMBER	DEPTH OF DRAIN SEAL	LENGTH	DRAIN DIAMETER
1.5 in. wc	LC1525-71-56	5.6 in.	7.5 in.	.75 in.
1.5 in. wc	LC1525-11-56	5.6 in.	7.5 in.	1.0 in.
1.5 in. wc	LC1525-77-56	5.6 in.	7.5 in.	.75 in.
1.5 in. wc	LC1525-17-56	5.6 in.	7.5 in.	1.0 in.

Table 1 defines the characteristics of the LC 1525 models. The depth (i.e., the distance between the centerline of the drain connection and the bottom of the unit) is 5.6 inches.

Commercial CXXXX

Model CXXXX is custom-designed for large draw-through air handlers. It is available for nominal drain diameters of 1-1/4", 1-1/2", and 2.0 inches and can operate with a negative static pressure in the drain pan of 5.0 inches wc or less.

In Figure 3, you can see a photograph of a custom-built model, along with a sketch defining its geometry. Units are fabricated to match the specific requirements of each air handler.

Like the LC1525 model, the device consists of three parts, identified in Figure 3 as Parts A, B, and C. This arrangement of parts provides versatility in installation. For example, by rotating Part C in Part A, the discharge port Part B can be pointed in various directions. Part B can also be rotated up to 60 degrees to allow piping alignment.

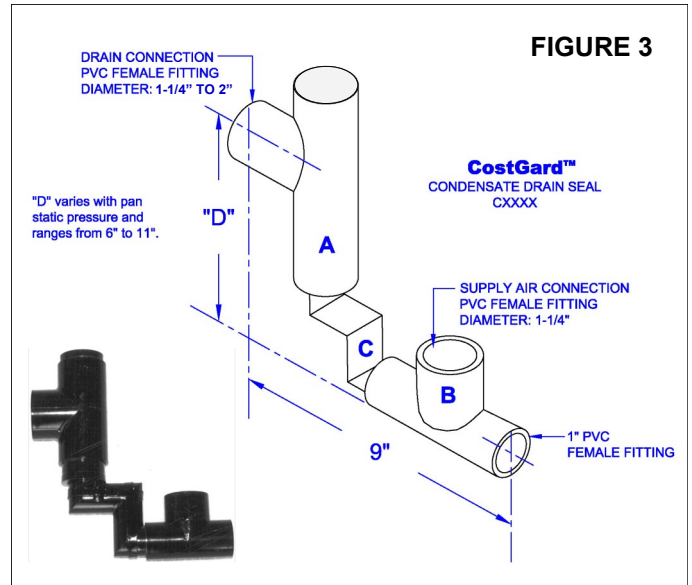

TABLE 2. COMMERCIAL CXXXX CostGard™ CONDENSATE DRAIN SEAL UNITS WITH COOLING CAPACITIES UP TO 100+ TONS

MAXIMUM NEGATIVE DRAIN PAN PRESSURE	MODEL NUMBER	DEPTH OF DRAIN SEAL	LENGTH	DRAIN DIAMETERS AVAILABLE			
				A	B	C	D*
2.5 in. wc	C2500	5.6 in.	9.0 in.	1.25 in.	1.5 in.	2.0 in.	1.0"
3.0 in. wc	C3000	6.7 in.	9.0 in.	1.25 in.	1.5 in.	2.0 in.	1.0"
3.5 in. wc	C3500	7.7 in.	9.0 in.	1.25 in.	1.5 in.	2.0 in.	1.0"
4.0 in. wc	C4000	8.7 in.	9.0 in.	1.25 in.	1.5 in.	2.0 in.	1.0"
4.5 in. wc	C4500	10.0 in.	9.0 in.	1.25 in.	1.5 in.	2.0 in.	1.0"
5.0 in. wc	C5000	11.0 in.	9.0 in.	1.25 in.	1.5 in.	2.0 in.	1.0"

*D, one inch drains have an additional pipe connection. See model CXXBV-11-10-XX-20-01-1-1

Table 2 defines the characteristics of the CXXXX model. The depth of these models, identified in Figure 3 as "D," depends on the pressure in the drain pan. As shown, a unit 11 inches deep will accommodate a negative pressure of 5 inches wc or less. Note that the minimum depth of the custom-built unit is 5.6 inches, which applies to all systems with negative drain pan pressure 2.5 inches wc and less. (If the unit depth and pan pressures listed in Table 2 are outside the design limits of the system, contact Trent Technologies, Inc. for a resolution.)

EXECUTION

Fundamentals

The CostGard™ Condensate Drain Seal is connected to the drain connection of the HVAC unit, the same as the condensate trap. However, in order to form an air seal, in place of a water seal, two additional pipe connections are required. For most applications these connections are quite simple; however, some can be more challenging. The basic criteria for a successful installation are stated below:

1. Pipe Connections*

The CostGard™ Condensate Drain Seal must be connected, with piping, to the HVAC system at the following three (3) points:

- The condensate drain pan connection where condensate traps are usually connected;
- the fan/drain pan compartment;** and
- air supply duct, or air supply plenum.

* Some manufacturers provide units "CostGard™ Ready" with penetrated panels.

** Improved CXXXX models no longer have the (b) connection.

2. Pipe Routing

All pipes must be routed to not interfere with service access doors.

3. Pipe Supports

The pipe must be supported and fixed in place in order to minimize potential damage to the piping and to the CostGard™ Condensate Drain Seal.

INSTALLATION

Examples of some possible installation arrangements, which meet the above criteria are shown to the right. Similar sketches for applicable HVAC units are included with each CostGard™ Condensate Drain Seal.

CostGard™ System Kits for unitary rooftop units up to 30 Tons, on pages 7 & 8, offer ease of installation. Kits are designed using a Light Commercial or Commercial CostGard™ Drain Seals and are manufacture brand and model specific.

MAINTENANCE

CostGard™ Condensate Drain Seal maintenance is virtually nil when compared to that of p-traps.

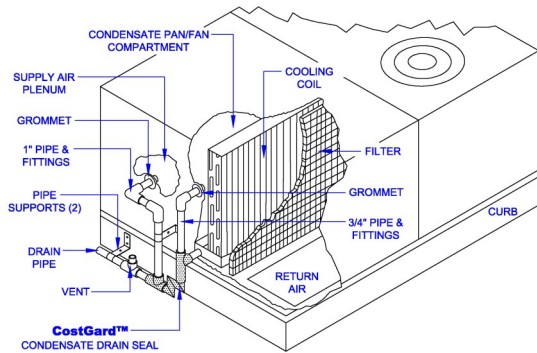

LIGHT COMMERCIAL SYSTEM KIT UNITARY RTU

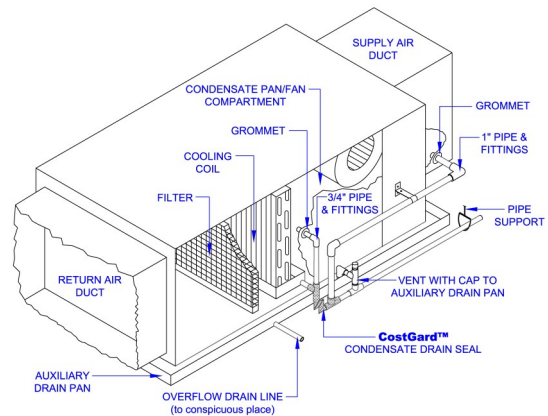

LIGHT COMMERCIAL LC1525 FAN COIL

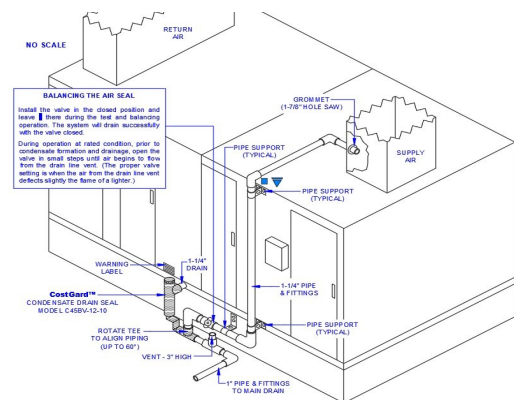

COMMERCIAL CXXXX LARGE AHU

Note: Most building codes require that drainpipes slope at least one-eighth (1/8) inch per foot toward the floor drain. Thus, for example, if the floor drain is located 16 feet away from the drain outlet, the curb height must be sufficient to accommodate the depth of the CostGard™ Condensate Drain Seal plus two (2) inches (16 x 1/8).

Trent Technologies, Inc.
15939 FM 2493, Tyler, TX 75703
(903) 509-4843
www.TrentTech.com

CostGard™ Condensate Drain Seal



Draw-Through

MODEL NUMBER DESCRIPTOR

LC 1525-X-X-XX-10-X-X-X

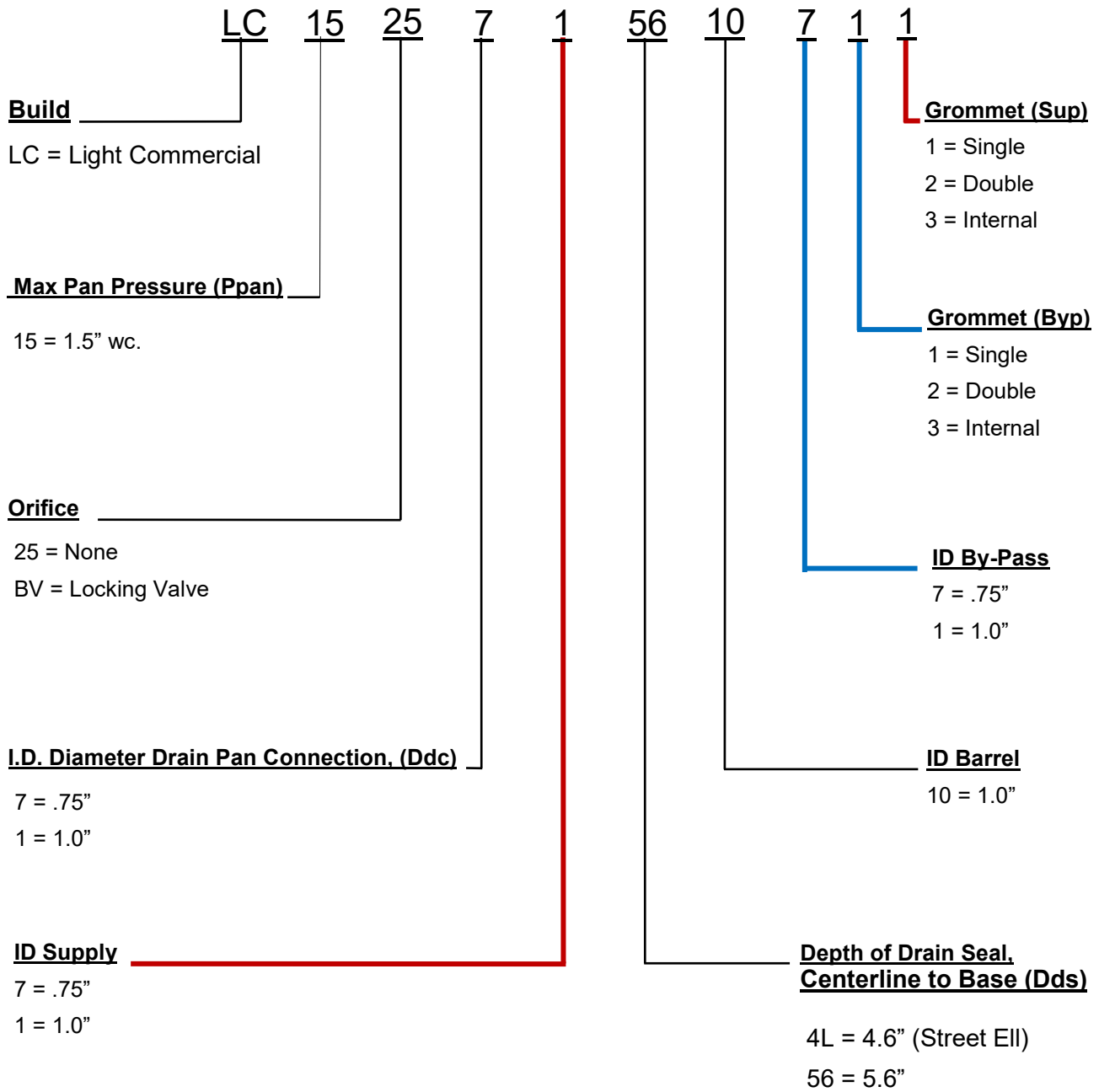



CostGard™ Condensate Drain Seal Draw-Through

MODEL NUMBER DESCRIPTOR

C XX-XX-XX-12-XX-20-XX-X-X

C 25 BV 10 12 4L 20 10 2 1

C 25 BV 12 12 56 20 25 2 1

Build

C = Commercial - Custom

Max Pan Pressure (Ppan)

25 = 2.5" wc. 40 = 4.0" wc.
30 = 3.0" wc. 45 = 4.5" wc.
35 = 3.5" wc. 50 = 5.0" wc.

Orifice

BV = Locking Valve 10 = 10/16
25 = None 11 = 11/16
08 = 8/16 12 = 12/16
09 = 9/16 14 = 14/16

I.D. Drain Pan Connection, (Ddc)

10 = 1.0" 15 = 1.5"
12 = 1.25" 20 = 2.0"

I.D. Supply

12 = 1.25"

Grommet (Sup)

1 = Single
2 = Double
3 = Internal

Grommet (Byp)

0 = None
1 = Single
2 = Double
3 = Internal

I.D. By-Pass

25 = None
10 = 1.0"

I.D. Barrel

20 = 2.0"

**Depth of Drain Seal,
Centerline to Base (Dds)**

4L = 4.6"
56 = 5.6"
70 = 7.0"
75 = 7.5"
80 = 8.0"
95 = 9.5"
11 = 11.0"

CostGard™ Unitary RTU System Kit

Unitary RTU System Kits are easy to specify and applicable to unitary rooftop units up to 30 tons with 3/4" or 1" drain sizes. These kits are designed for most major manufacturers' unitary rooftop units, including Trane, Carrier, York, Lennox, Aeon, Daikin, Rudd, Rheem, and others. All components are UV-inhibited and engineered for performance and easy installation. The drain seal static pressure limit is negative up to -2.0" w.c.

[This link provides a list of available kits, along with their model numbers. Specifiers can use the RTU manufacturer's model number to specify for units not listed here.](#)



Typical **CostGard™** RTU System Kit Components